



A U D I O

804 CALLE PLANO, CAMARILLO, CA 93012 - 888.340.4403 - WWW.ILLUSIONAUDIO-AMERICA.COM

CARBON C3



DRIVER SPECIFICATIONS

- Woven carbon fiber cone with rubber surround
- Cast aluminum basket
- Black aluminum phase plug
- 26 mm voice coil
- Minimum sealed box volume: 0.5 liter or 30 in³
- Recommended high pass electronic cover: 250 Hz 12 dB Linkwitz-Riley

Fs	106 Hz
Re	3.22 Ohms
Qms	6.23
Qes	0.67
Qts	0.61
Le	0.1 mH
Vas	.95 liter
Mms	3.2 gram
Cms	6.99 uM/Newton
Bl	3.2 Tesla-M
SPLref	88 dB
Sd	24 sq cm
Xmax	+/- 4mm
Xsus	+/- 6mm

Nominal Power	50 watts
Maximum Power	100 watts
Outside Diameter	88 mm basket
Mount Hole	75 mm
Mount Depth	38 mm
Weight	234 gram

CROSSOVER, SINGLE AMP OR BI AMP

- 2000 Hz, 12 dB Linkwitz-Riley
- Polypropylene capacitors and air core inductors
- 7 position tweeter loudness adjustment
- Tweeter overload protection
- Dimensions: 131 x 84 x 38 mm

COMPONENT TWEETER

- 25 mm Beryllium Copper
- Low resonance frequency air chamber aluminum heatsink
- 4 ohm

Outside Diameter	48.2 mm
Mount Hole	43.5 mm
Mount Depth	24 mm
Weight	63 gram

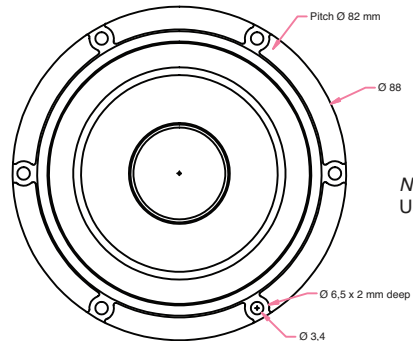

NOTE:
Use #4 Size Screw

